



Micromatic

HIGH PRESSURE - HOLLOW SHAFT

6 Standard Sizes

3,000 PSI

Up to 57,000 in/lbs of Torque

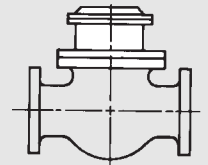
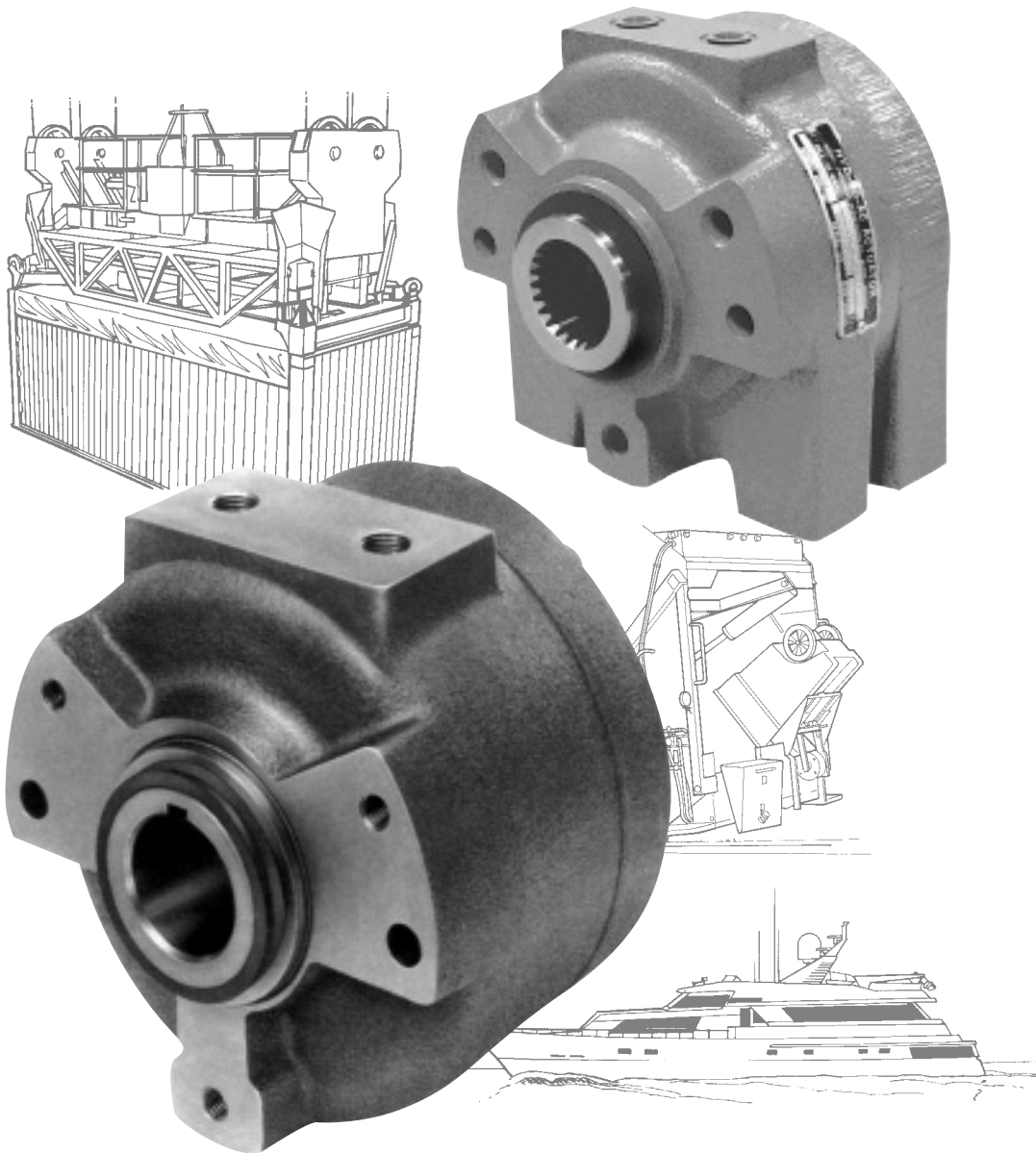

VALVE OPEN—CLOSE

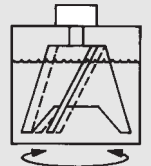

MIX—STIR

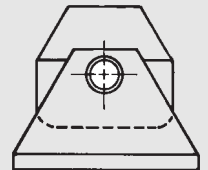

TURNOVER—DUMP

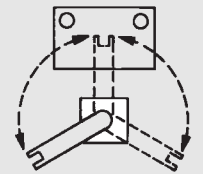

LOAD—POSITION—UNLOAD

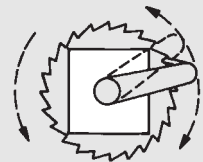

CONTINUOUS ROTATION



TURN—OSCILLATE

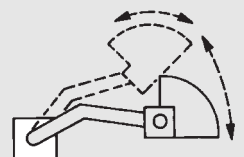

MATERIAL HANDLING

PROVIDING the “MUSCLE” for your lifting, turning, indexing, opening, closing, clamping, mixing, bending, testing, steering . . . **applications.**

HS MODELS

**END MOUNTING
HIGH PRESSURE 3000 PSI *1**

SINGLE VANE HS-1.5, HS-2.5, HS-4

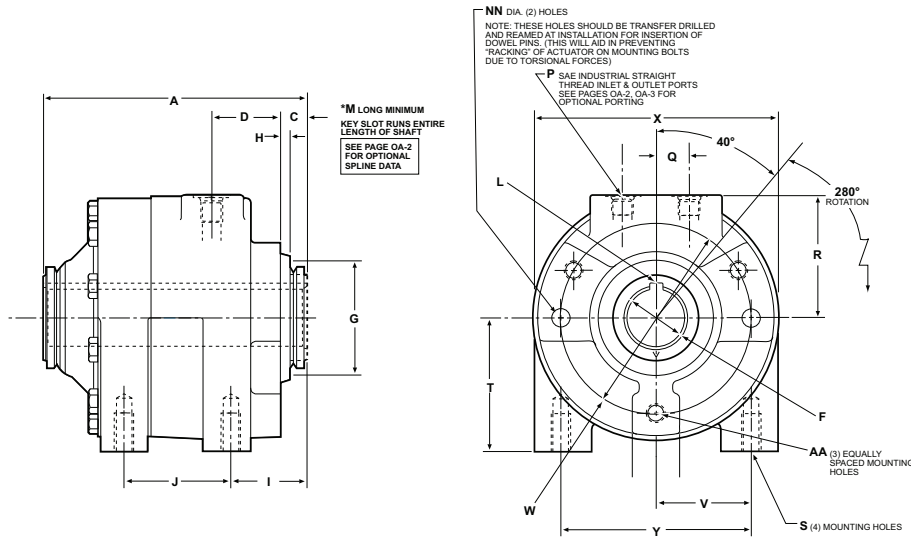

SINGLE VANE HS-6, HS-10, HS-15

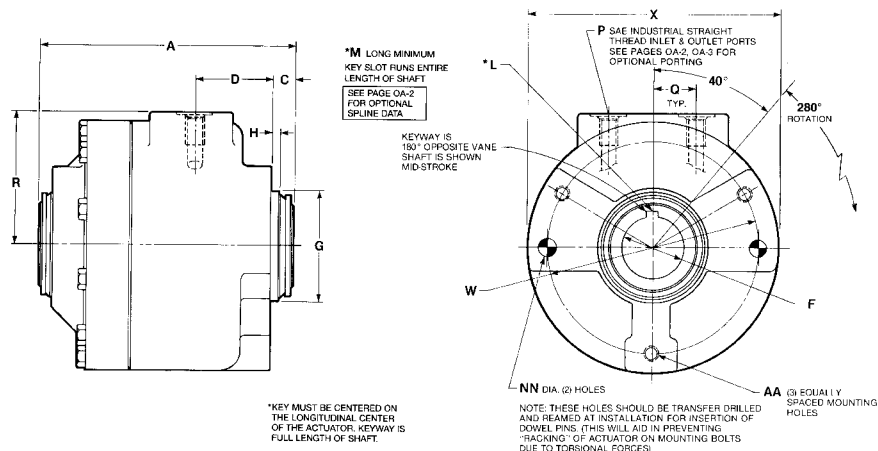

DOUBLE VANE

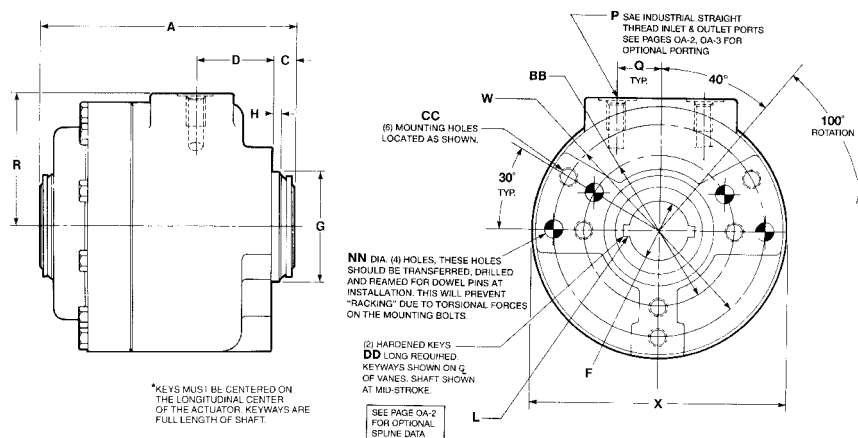

NOTE: See cut away view of 1V model on page 46.

NOTE: See pages 55 for optional manifold.

*1 2000 PSI maximum is recommended for severe duty applications, such as operating at maximum torque at high cycle rates for extended periods. Please consult factory for applications beyond 2000 PSI. 3000 PSI can be used on intermittent shockless actuations.

APPLICATION DATA DIMENSIONS IN INCHES (METRIC)

	HS-1.5	HS-2.5	HS-4	HS-6	HS-10	HS-15
A	6.12 (155.45)	6.92 (175.77)	8.12 (206.25)	7.25 (184.15)	8.25 (209.55)	9.97 (253.24)
C	.69 (17.53)	.69 (17.53)	.69 (17.53)	.69 (17.53)	.69 (17.53)	.69 (17.53)
D	1.81 (45.97)	1.81 (45.97)	1.81 (45.97)	2.50 (63.50)	2.50 (63.50)	2.50 (63.50)
① F	1.5020 (38.151)	1.5020 (38.151)	1.5020 (38.151)	2.0025 (50.864)	2.0025 (50.864)	2.0025 (50.864)
② G	2.9990 (76.175)	2.9990 (76.175)	2.9990 (76.175)	3.6240 (92.050)	3.6240 (92.050)	3.6240 (92.050)
⑤ H	.25 (6.35)	.25 (6.35)	.25 (6.35)	.25 (6.35)	.25 (6.35)	.25 (6.35)
I	2.00 (50.8)	2.00 (50.8)	2.00 (50.8)			
J	2.00 (50.8)	2.80 (71.12)	4.00 (101.6)			
③ L	$\frac{5}{16} \times \frac{5}{32}$ (7.94 x 3.96)	$\frac{5}{16} \times \frac{5}{32}$ (7.94 x 3.96)	$\frac{5}{16} \times \frac{5}{32}$ (7.94 x 3.96)	$\frac{3}{8} \times \frac{3}{16}$ (9.53 x 4.76)	$\frac{3}{8} \times \frac{3}{16}$ (9.53 x 4.76)	$\frac{3}{8} \times \frac{3}{16}$ (9.53 x 4.76)
M	1.38 (35.03)	2.25 (57.15)	3.50 (88.90)	3.00 (76.2)	4.50 (114.30)	7.00 (177.80)
④ P	$\frac{9}{16}$ -18 (22.352)	$\frac{9}{16}$ -18 (22.352)	$\frac{9}{16}$ -18 (22.352)	$\frac{3}{4}$ -16 (36.50)	$\frac{3}{4}$ -16 (36.50)	$\frac{3}{4}$ -16 (36.50)
Q	.88 (22.352)	.88 (22.352)	.88 (22.352)	1.437 (36.50)	1.437 (36.50)	1.437 (36.50)
R	3.22 (81.79)	3.22 (81.79)	3.22 (81.79)	4.44 (112.78)	4.44 (112.78)	4.44 (112.78)
S	$\frac{1}{2}$ -13 1.00 DP	$\frac{1}{2}$ -13 1.00 DP	$\frac{1}{2}$ -13 1.00 DP			
T	3.50 (88.9)	3.50 (88.9)	3.50 (88.9)			
V	2.50 (63.5)	2.50 (63.5)	2.50 (63.5)			
W	5.00 (127.00)	5.00 (127.00)	5.00 (127.00)	7.00 (177.80)	7.00 (177.80)	7.00 (177.80)
X	6.25 (158.75)	6.25 (158.75)	6.25 (158.75)	8.50 (215.90)	8.50 (215.90)	8.50 (215.90)
④ Y	5.00 (127.00)	5.00 (127.00)	5.00 (127.00)			
AA	$\frac{1}{2}$ -13 1.00 DP	$\frac{1}{2}$ -13 1.00 DP	$\frac{1}{2}$ -13 1.00 DP	$\frac{1}{2}$ -13 1.00 DP	$\frac{1}{2}$ -13 1.00 DP	$\frac{1}{2}$ -13 1.00 DP
BB	— (25.4)	— (25.4)	— (25.4)	5.00 (127.0)	5.00 (127.0)	5.00 (127.0)
CC	—	—	—	$\frac{5}{8}$ -11 1.13 DP	$\frac{5}{8}$ -11 1.13 DP	$\frac{5}{8}$ -11 1.13 DP
DD	—	—	—	7.25 (184.15)	8.25 (209.55)	9.97 (253.24)
NN	.468 (11.89) 1.25 DP (31.75)	.468 (11.89) 1.25 DP (31.75)	.468 (11.89) 1.25 DP (31.75)	.593 (15.06) 1.25 DP (31.75)	.593 (15.06) 1.25 DP (31.75)	.593 (15.06) 1.25 DP (31.75)

- ① TOLERANCE ± .001 (0.0254) HS-1.5, 2.5, 4
± .0015 (0.038) HS-6, 10, 15
- ② TOLERANCE ± .001 (0.0254)
- ③ SEE PAGE OA-2 FOR OPTIONAL SPLINE DATA
- ④ SEE PAGES OA-2, OA-3 FOR OPTIONAL PORT DATA
- ⑤ TOLERANCE ± .001

NOTE: See how to order on page 46.

PERFORMANCE

SINGLE VANE 280° ROTATION (±5°)						
MODEL	TORQUE IN-LBS (N•m)			VOLUMETRIC DISPLACEMENT IN ³ (cm ³)		APPROX. WEIGHT LB (Kg)
	1000 PSI (69.0 BAR)	2000 PSI (137.9 BAR)	3000 PSI (206.9 BAR)	PER 280°	PER RAD	
	HS-1.5	1350 (152.55)	2700 (305.10)	4050 (457.65)	7.30 (119.64)	
HS-2.5	2250 (254.25)	4500 (508.50)	6750 (762.75)	12.20 (199.95)	2.50 (40.97)	34 (15.42)
HS-4	3600 (406.80)	7200 (813.60)	10800 (1220.40)	19.54 (320.26)	4.00 (65.56)	41 (18.59)
HS-6	5720 (646.36)	11440 (1292.72)	17160 (1939.08)	31.05 (508.90)	6.36 (104.24)	58 (26.30)
HS-10	8600 (971.80)	17200 (1943.60)	25800 (2915.40)	46.59 (763.61)	9.54 (156.36)	67 (30.39)
HS-15	13500 (1525.50)	27000 (3051.00)	40500 (4576.50)	73.27 (1200.89)	15.00 (245.85)	83 (37.64)

DOUBLE VANE 100° ROTATION (±5°)						
MODEL	TORQUE IN-LBS (N•m)			VOLUMETRIC DISPLACEMENT IN ³ (cm ³)		APPROX. WEIGHT LB (Kg)
	1000 PSI (69.0 BAR)	2000 PSI (137.9 BAR)	3000 PSI (206.9 BAR)	PER 100°	PER RAD	
	HS-1.5			NA		
HS-2.5			NA			
HS-4			NA			
HS-6	12080 (1365.04)	24170 (2731.21)	36250 (4096.25)	22.20 (363.86)	12.72 (208.48)	68 (30.84)
HS-10	18120 (2047.56)	36250 (4096.25)	54370 (6143.81)	33.29 (545.62)	19.08 (312.72)	76 (34.47)
HS-15	28500 (3220.50)	57000 (6441.00)	NA	52.70 (863.75)	30.02 (492.03)	95 (43.08)

TEST PARAMETERS — OIL			
MODEL	MAX BREAK IN PSI (BAR)	BY-PASS LEAKAGE-MAX ALLOWABLE	
		CUBIC IN. PER MIN. AT 3000 PSI (206.9 BAR)	CUBIC CM. PER MIN. AT 3000 PSI (206.9 BAR)
		HS-1.5	80 (5.52)
HS-2.5	80 (5.52)	6	98
HS-4	80 (5.52)	7	115
HS-6	50 (3.44)	8	131
HS-10	50 (3.44)	9	148
HS-15	50 (3.44)	10	164

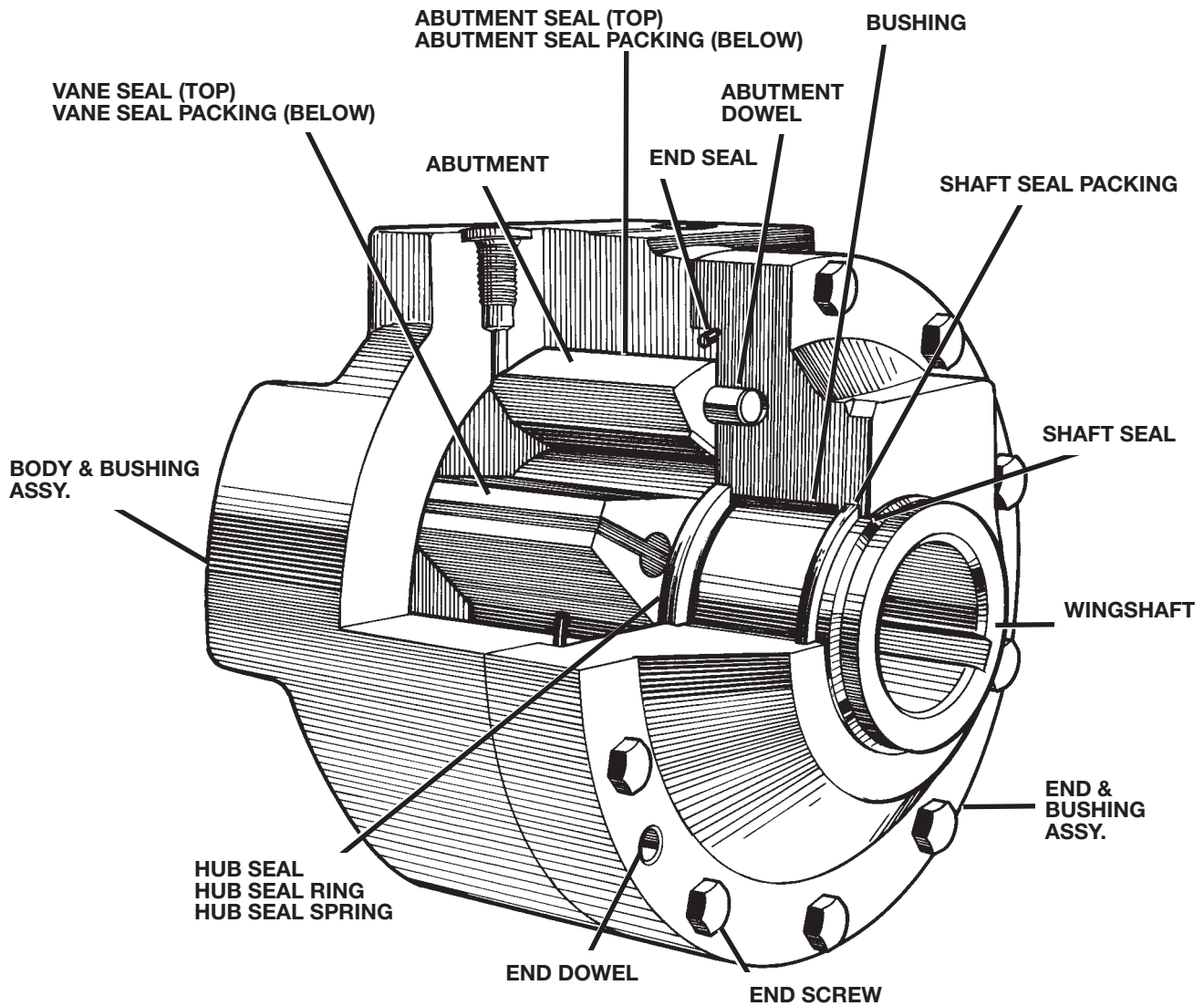

HOW TO ORDER

Please fill in ALL blocks in accordance with the KEY numbers and letters shown below.

Block #

1 2 3 4 5 6 7 8

Block 1 (STYLE)

HS Hollow shaft

Block 2 (SIZE)

1 1/2

2 1/2

4

6

10

15

Block 3 (NO. OF VANES)

1V Single vane

2V Double vane

Block 4 (MOUNTING)

E End

B Base (Available in sizes 1-1/2, 2-1/2 & 4 only.)

Block 5 (SEALS)

B Buna "N" Standard shaft seal

V Viton Standard shaft seal

E Ethylene propylene

Z Special

Block 6 (SHAFT CONFIGURATION)

A Standard (Internal key for HS)

M Internal spline (HS)

Z Special

Block 7 (SHAFT MODIFICATION)

A Standard (None)

Z Special

Block 8 (PORTING)

1 N.P.T.

2 SAE Straight threads standard

** 5 End ports—N.P.T.

** 6 End ports—SAE

7 Manifold ports (See manifold porting data for explanation)

0 BSPP straight threads

Z Special

** "End ports" for HS Series means on non-mounting end, parallel to shaft.

Not available on 2V units.