

## Straight Bulkhead (Metric)

### Benefits

- Leak free “O” ring seal.
- Safe joint every time – low tightening torque and clamping forces rise with the internal pressure.
- Low installed cost – no welding (so inert gas purging, NDT and excessive flushing are not required), minimal tube preparation and no special assembly equipment are required.
- Demountable and reusable. Can be used with most tube materials.

### Features

1. Body – mild steel, compatible with most fluids and environments. Locates O-ring and tube.
2. O-ring – nitrile, compatible with most fluids, highly resistant to leakage even under severe vibration, pressure pulsation and temperature cycling. Provides diametric seal between the O/D and body cavity.
3. Nut - mild steel, compatible with environments. Closes split collet and retains sealing mechanism.
4. Back-up washer – mild steel. Provides additional support for the tube and locates the O-ring.
5. Split collet – mild steel. Clamping force rises with pressure. Large clamping area ensures minimal deformation of the tube. Retains tube in position.

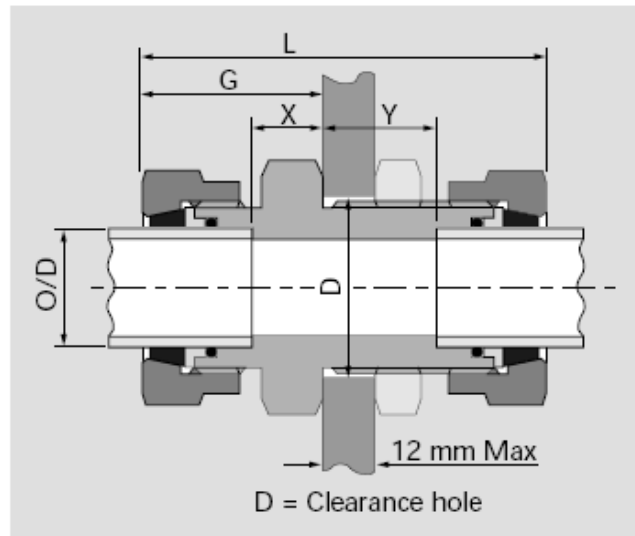

Primary Item No	O/D mm	Part No	D mm	G mm	L mm	X mm	Y mm	Nut A/F mm	Body A/F mm	Max WP Bar
5011904	6	KRAM6BPR	14	25	67	10	27	16	17	680
5011956	8	KRAM8BPR	16	25	67	10	27	17	17	680
5011455	10	KRAM10BPR	24	30	76	8	24	27	27	680
5011528	12	KRAM12BPR	24	30	76	8	24	27	27	680
5011602	16	KRAM16BPR	27	33	82	10	25	32	32	680
5011665	20	KRAM20BPR	37	46	101	16	32	41	41	680
5011695	22	KRAM22BPR	37	43	99	13	25	41	41	680
5011731	25	KRAM25BPR	40	49	109	18	34	46	41	500
5011784	30	KRAM30BPR	46	51	115	18	32	50	50	500
5011826	38	KRAM38BPR	52	62	134	23	34	60	60	500
5011859	50	KRAM50BPR	71	79	171	29	42	80	80	500

**Supplied By**  
 Primary Fluid Power Limited  
 Caddick Road  
 Knowsley Business Park  
 L34 9HP  
 Tel No. +44(0)151 632 9500  
 Fax No. +44(0)151 548 9896  
[www.PrimaryFP.co.uk](http://www.PrimaryFP.co.uk)