

Straight Bulkhead (Imperial)

Benefits

- Leak free “O” ring seal.
- Safe joint every time – low tightening torque and clamping forces rise with the internal pressure.
- Low installed cost – no welding (so inert gas purging, NDT and excessive flushing are not required), minimal tube preparation and no special assembly equipment are required.
- Demountable and reusable. Can be used with most tube materials.

Features

1. Body – mild steel, compatible with most fluids and environments. Locates O-ring and tube.
2. O-ring – nitrile, compatible with most fluids, highly resistant to leakage even under severe vibration, pressure pulsation and temperature cycling. Provides diametric seal between the O/D and body cavity.
3. Nut - mild steel, compatible with environments. Closes split collet and retains sealing mechanism.
4. Back-up washer – mild steel. Provides additional support for the tube and locates the O-ring.
5. Split collet – mild steel. Clamping force rises with pressure. Large clamping area ensures minimal deformation of the tube. Retains tube in position.

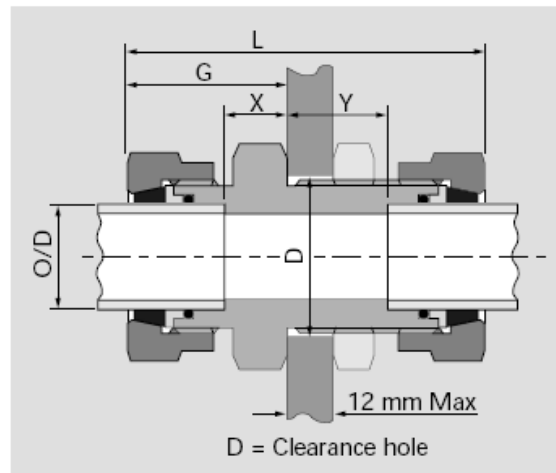

Primary Item No	O/D	Part No	D mm	G mm	L mm	X mm	Y mm	Nut A/F mm	Body A/F mm	Max WP Bar
5012318	1/4"	KRA4BPR	14	25	67	10	27	16	17	680
5011956	5/16"	KRA5BPR	16	25	67	10	27	17	17	680
5012427	3/8"	KRA6BPR	17	27	72	11	27	19	19	680
5012495	1/2"	KRA8BPR	24	30	76	8	24	27	27	680
5011602	5/8"	KRA10BPR	27	33	82	10	25	32	32	680
5012068	3/4"	KRA12BPR	30	39	91	13	26	33	33	680
5011695	7/8"	KRA14BPR	37	43	99	13	25	41	41	680
5012159	1"	KRA16BPR	40	46	105	15	28	46	41	500
5012200	1-1/4"	KRA20BPR	46	51	115	18	32	50	50	500
5011826	1-1/2"	KRA24BPR	52	62	134	23	34	60	60	500
5012270	2"	KRA32BPR	71	79	171	29	42	80	80	500

Supplied By
 Primary Fluid Power Limited
 Caddick Road
 Knowsley Business Park
 L34 9HP
 Tel No. +44(0)151 632 9500
 Fax No. +44(0)151 548 9896
www.PrimaryFP.co.uk