



EGESD-SRWD Stud Standpipe Adaptor

Features:

- Two edge cutting ring.
- Cone stop limit to prevent over tightening.
- 6mm to 42mm OD tube sizes in (L) light and (S) heavy series.
- Best cutting ring pressure performance.

Benefits:

- Reliable first time assembly.
- High sealing efficiency for cutting ring technology.
- High nominal pressure L Series - up to 600 bar S Series - up to 800 bar.
- Available in stainless steel body & nut on request * WalproX stainless ring now available.

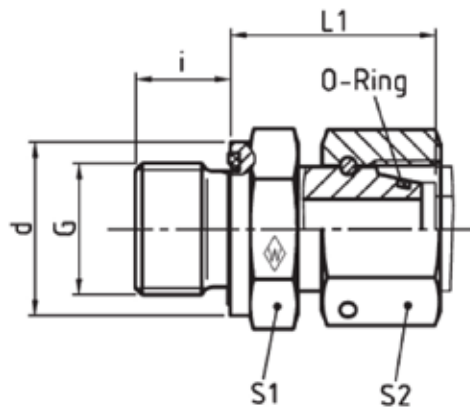

Primary Item No	Tube O/D	Thread BSP	Part No	L1 mm	i mm	d mm	S1 A/F mm	S2 A/F mm	O-Ring	Max WP Bar
5070402	6	1/4"	EGESD6SRWD	27	12	18,9	19	17	4,5x1,5	800
5070404	8	1/4"	EGESD8SRWD	29,5	12	18,9	19	19	6x1,5	800
5070392	10	3/8"	EGESD10SRWD	32	12	21,9	22	22	8,5x1,5	800
5070395	12	3/8"	EGESD12SRWD	34	12	21,9	22	24	10x1,5	630
5070394	12	1/2"	EGESD12SR-1/2WD	34,5	14	26,9	27	24	10x1,5	630
5070396	16	1/2"	EGESD16SRWD	37	14	26,9	27	30	14x2	630
5070397	20	3/4"	EGESD20SRWD	43	16	31,9	32	36	17,3x2,4	420
5070398	25	1"	EGESD25SRWD	47	18	39,9	41	46	22,3x2,4	420
5070399	30	1-1/4"	EGESD30SRWD	51	20	49,9	50	50	27,3x2,4	400
5070400	38	1-1/2"	EGESD38SRWD	60	22	54,9	55	60	35x2,5	400