



ELVD-S Adjustable Male Stud Tee-Stud Barrel

Benefits

- Reliable first time assembly.
- High sealing efficiency for cutting ring technology.
- High nominal pressure L Series - up to 600 bar S Series - up to 800 bar.
- Available in stainless steel body & nut on request * WalproX stainless ring now available.

Features

- Two edge cutting ring.
- Cone stop limit to prevent over tightening.
- 6mm to 42mm OD tube sizes in (L) light and (S) heavy series.
- Best cutting ring pressure performance.

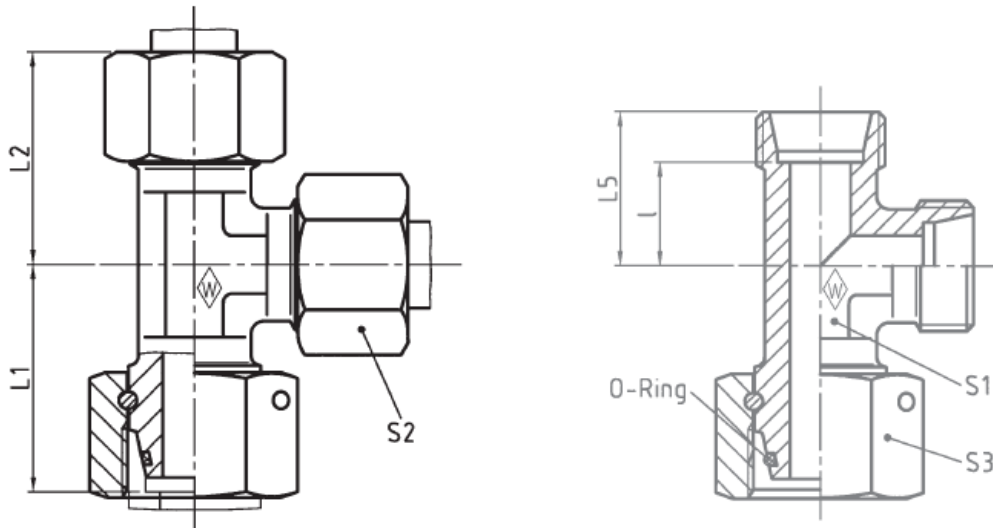

Primary Item No	Tube O/D	Part No	L1 mm	L2 mm	L5 mm	I mm	S1 A/F mm	S2 A/F mm	S3 A/F mm	O'Ring	Max WP Bar
5070412	6	P-ELVD6S	27	31	23	16	12	17	17	4,5x1,5	800
5070413	8	P-ELVD8S	27,5	32	24	17	14	19	19	6x1,5	800
5070405	10	P-ELVD10S	30	34	25	17,5	17	22	22	8,5x1,5	800
5070406	12	P-ELVD12S	31	38	29	21,5	17	24	24	10x1,5	630
5070407	16	P-ELVD16S	36,5	43	33	24,5	24	30	30	14x2	630
5070408	20	P-ELVD20S	44,5	48	37	26,5	27	36	36	17,3x2,4	420
5070409	25	P-ELVD25S	50	54	42	30	36	46	46	22,3x2,4	420
5070410	30	P-ELVD30S	55	62	49	35,5	41	50	50	27,3x2,4	400
5070411	38	P-ELVD38S	63	72	57	41	50	60	60	35x2,5	400

Supplied By
 Primary Fluid Power Limited
 Caddick Road
 Knowsley Business Park
 L34 9HP
 Tel No. +44(0)151 632 9500
 Fax No. +44(0)151 548 9896
www.PrimaryFP.co.uk