



GAV-SR Female Stud Coupling

Features:

- Two edge cutting ring.
- Cone stop limit to prevent over tightening.
- 6mm to 42mm OD tube sizes in (L) light and (S) heavy series.
- Best cutting ring pressure performance.

Benefits:

- Reliable first time assembly.
- High sealing efficiency for cutting ring technology.
- High nominal pressure L Series - up to 600 bar S Series - up to 800 bar.
- Available in stainless steel body & nut on request * WalproX stainless ring now available.

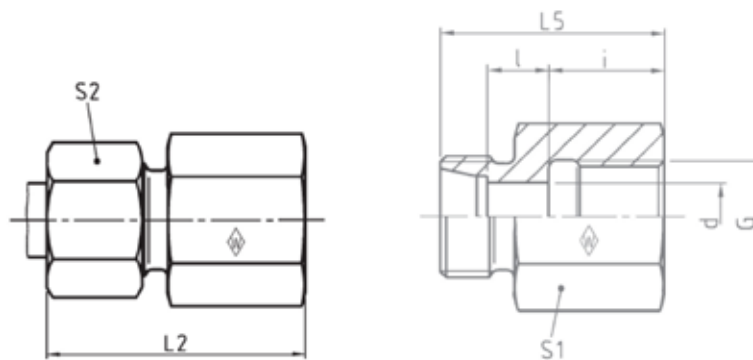

Primary Item No	Tube O/D	Thread BSP	Part No	L2 mm	L5 mm	l mm	i mm	d mm	S1 A/F mm	S2 A/F mm	Max WP Bar
5070327	6	1/4"	P-GAV6SR	41	33	9	17	4	19	17	630
5070329	8	1/4"	P-GAV8SR	41	33	9	17	5	19	19	630
5070320	10	3/8"	P-GAV10SR	43	34	9,5	17	7	24	22	630
5070324	12	3/8"	P-GAV12SR	43	34	9,5	17	8	24	24	630
5070325	16	1/2"	P-GAV16SR	50	40	11,5	20	12	30	30	400
5070916	20	3/4"	P-GAV20SR	56	45	12,5	22	16	36	36	400
5070918	25	1"	P-GAV25SR	62	49,5	13	24,5	20	41	46	400
5070920	30	1-1/4"	P-GAV30SR	69	55,5	15,5	26,5	25	55	50	250
5070922	38	1-1/2"	P-GAV38SR	74	59,5	15	28,5	32	60	60	250