



EGESD-LRWD Stud Standpipe Adaptor

Features:

- Two edge cutting ring.
- Cone stop limit to prevent over tightening.
- 6mm to 42mm OD tube sizes in (L) light and (S) heavy series.
- Best cutting ring pressure performance.

Benefits:

- Reliable first time assembly.
- High sealing efficiency for cutting ring technology.
- High nominal pressure L Series - up to 600 bar S Series - up to 800 bar.
- Available in stainless steel body & nut on request * WalproX stainless ring now available.

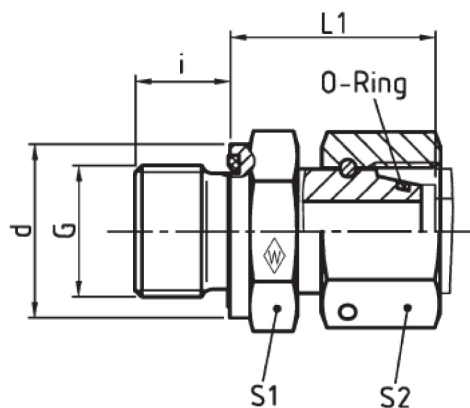

Primary Item No	Tube O/D	Thread BSP	Part No	L1 mm	i mm	d mm	S1 A/F mm	S2 A/F mm	O-Ring	Max WP Bar
5070401	6	1/8"	EGESD6LRWD	24,5	8	13,9	14	17	4,5x1,5	500
5070403	8	1/4"	EGESD8LRWD	29,5	12	18,9	19	17	6x1,5	500
5070391	10	1/4"	EGESD10LRWD	27,5	12	18,9	19	19	8,5x1,5	500
5070393	12	1/4"	EGESD12LR-1/4WD	27,5	12	18,9	19	22	10x1,5	400
5070536	12	3/8"	EGESD12LRWD	34	12	21,9	22	22	10x1,5	400
5070541	15	1/2"	EGESD15LRWD	32	14	26,9	27	27	12x2	400
5070545	18	1/2"	EGESD18LSRWD	31,5	14	26,9	27	32	15x2	400
5070548	22	3/4"	EGESD22LRWD	32,5	16	31,9	32	36	20x2	250
5070551	28	1"	EGESD28LRWD	35	18	39,9	41	46	26x2	250
5070554	35	1-1/4"	EGESD35LRWD	42,5	20	49,9	50	50	32x2,5	250
5070557	42	1-1/2"	EGESD42LRWD	46,5	22	54,9	60	60	38x2,5	250