



GAV-LR Female Stud Coupling

Features:

- Two edge cutting ring.
- Cone stop limit to prevent over tightening.
- 6mm to 42mm OD tube sizes in (L) light and (S) heavy series.
- Best cutting ring pressure performance.

Benefits:

- Reliable first time assembly.
- High sealing efficiency for cutting ring technology.
- High nominal pressure L Series - up to 600 bar S Series - up to 800 bar.
- Available in stainless steel body & nut on request * WalproX stainless ring now available.

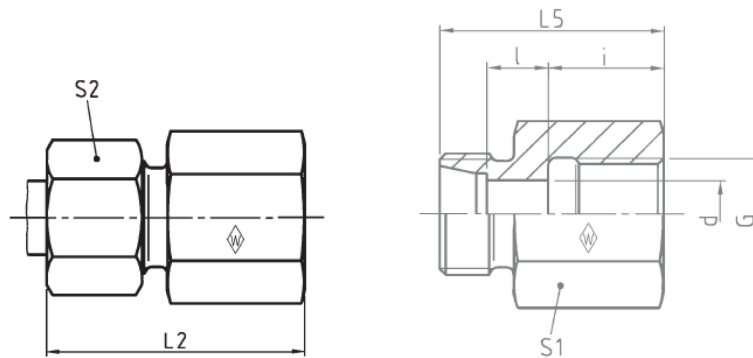

Primary Item No	Tube O/D	Thread BSP	Part No	L2 mm	L5 mm	l mm	i mm	d mm	S1 A/F mm	S2 A/F mm	Max WP Bar
5070326	6	1/8"	P-GAV6LR	34	26	7	12	4	14	14	250
5076071	6	1/4"	P-GAV6LR-1/4	39	31	7	17	4	14	19	250
5070328	8	1/4"	P-GAV8LR	39	31	7	17	6	19	17	250
5070319	10	1/4"	P-GAV10LR	40	32	8	17	8	19	19	250
5070322	12	1/4"	P-GAV12LR-1/4	40	32	8	17	8	19	22	250
5070323	12	3/8"	P-GAV12LR	41	33	9	17	10	24	22	250
5070321	12	1/2"	P-GAV12LR-1/2	46	37	10	20	10	27	22	250
5070914	15	1/2"	P-GAV15LR	46	38	11	20	12	30	27	250
5070915	18	1/2"	P-GAV18LR	47	38	10,5	20	15	27	32	160
5070917	22	3/4"	P-GAV22LR	52	43	13,5	22	19	36	36	160
5070919	28	1"	P-GAV28LR	55	45,5	13,5	24,5	24	41	41	100
5070921	35	1-1/4"	P-GAV35LR	63	51,5	14,5	26,5	30	55	50	100
5070923	42	1-1/2"	P-GAV42LR	65	53,5	14	28,5	36	60	60	100