



GEV-LRWD Male Stud Coupling

Benefits

- Reliable first time assembly.
- High sealing efficiency for cutting ring technology.
- High nominal pressure L Series - up to 600 bar S Series - up to 800 bar.
- Available in stainless steel body & nut on request * WalproX stainless ring now available.

Features

- Two edge cutting ring.
- Cone stop limit to prevent over tightening.
- 6mm to 42mm OD tube sizes in (L) light and (S) heavy series.
- Best cutting ring pressure performance.

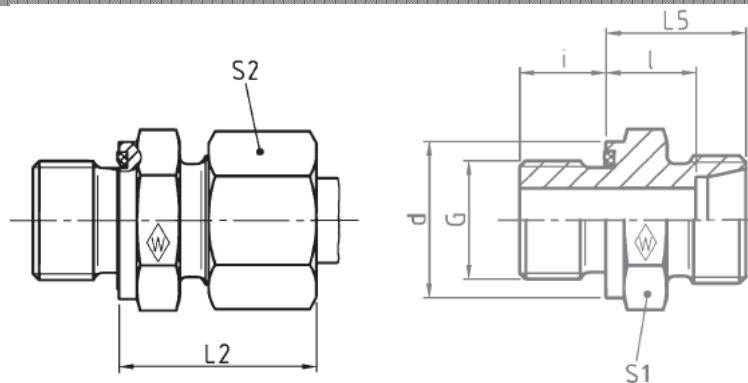

Primary Item No	Tube O/D	Thread BSP	Part No	L2 mm	L5 mm	l mm	i mm	d mm	S1 mm	A/F	S2 A/F	Max WP Bar
5070254	6	1/8"	P-GEV6LRWD	23	15,5	8,5	8	13,9	14	14	500	
5071031	6	1/4"	P-GEV6LR-1/4WD	24,5	17	10	12	18,9	19	14	500	
5070256	8	1/8"	P-GEV8LR-1/8WD	24	16,5	9,5	8	13,9	14	17	500	
5070258	8	1/4"	P-GEV8LRWD	25	17	10	12	18,9	19	17	500	
5070257	8	3/8"	P-GEV8LR-3/8WD	26	18,5	11,5	12	21,9	22	17	400	
5070233	10	1/4"	P-GEV10LRWD	26	18	11	12	18,9	19	19	500	
5070232	10	3/8"	P-GEV10LR-3/8WD	27	19,5	12,5	12	21,9	22	19	500	
5070231	10	1/2"	P-GEV10LR-1/2WD	27,5	21	13	14	26,9	27	19	500	
5070237	12	1/4"	P-GEV12LR-1/4WD	27	19	12	12	18,9	19	22	400	
5070238	12	3/8"	P-GEV12LRWD	27	19,5	12,5	12	21,9	22	22	400	
5074097	12	1/2"	P-GEV12LR-1/2WD	28	20	13	14	26,9	27	22	400	
5074098	15	3/8"	P-GEV15LR-3/8WD	29	20,5	14	12	21,9	27	27	400	
5070242	15	1/2"	P-GEV15LRWD	28,5	21	13,5	14	26,9	24	27	400	
5070244	18	1/2"	P-GEV18LRWD	31	22	14,5	14	26,9	27	32	400	
5074099	18	3/4"	P-GEV18LR-3/4WD	31	22	14,5	16	31,9	32	32	400	
5070246	22	3/4"	P-GEV22LRWD	33	24	16,5	14	26,9	32	36	250	
5070249	28	1"	P-GEV28LRWD	34	25	17,5	18	39,9	41	41	250	
5070251	35	1-1/4"	P-GEV35LRWD	39	28	17,5	20	49,9	50	50	250	
5070253	42	1-1/2"	P-GEV42LRWD	42	30	19	22	54,9	55	60	250	

Supplied By
Primary Fluid Power Limited
Caddick Road
Knowsley Business Park
L34 9HP
Tel No. +44(0)151 632 9500
Fax No. +44(0)151 548 9896
www.PrimaryFP.co.uk