

LEVEL GAUGES

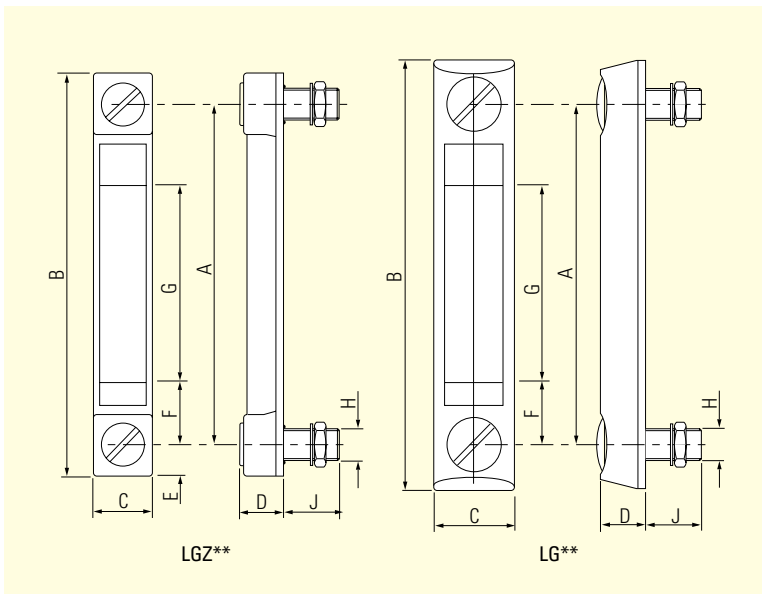

Specification

- Ultrasonically welded polyamid material
- Suitable for use with pressurised tanks
- Max. wall thickness - 12.7mm (LG3 & 5)
- 19mm (LG10)
- For use with most hydraulic fluids & mineral oils (not alcohol or alcohol based fluids).
- Maximum operating temperature +90° C.
- Tightening torque 15Nm.

Part number	Description	Dimensions - mm								
		A	B	C	D	E	F	G	H	J
LG3 ●	76 mm standard	76	106	27	16	15	18	34	M10	21
LG5 ●	127 mm standard	127	161	31	18	17	23	74	M12	23
LG10 ●	254 mm standard	254	290	35	18	18	26	193	M12	21
LGZ3 ●	76 mm low cost	76	99	22	16	12	18	34	M10	23
LGZ5 ●	127 mm low cost	127	150	22	17	12	23	74	M12	23

Thermometer code

Replace ● with appropriate code:

Blank - None

T - Thermometer