



4610/11/14 Series Filter Assemblies

Description

Featuring Coreless Element Technology

Flows to 70 gpm (265 L/min)

Pressures to 6500 psi (450 bar)

Port sizes: 1" and 1-1/4"



Specifications

Features

- Optional Differential Pressure Devices
- Patented Sealing Interface - Positive sealing with standard O-rings
- Forged Steel Bowl
- Ductile Iron Head
- Full Flow Fast Response Bypass Valve
- Sampling or Bleed Port
- Ultipor® III Element
- Optional 1/4" Drain Port

Maximum Acceptable Working Pressure:

6500 psi (450 bar)

Fatigue Pressure Rating:

(NFPA/T2.6.1-1991 category B/90)

5800 psi (400 bar) Stainless steel indicators required above 3000 psi (207 bar) RFP

Typical Burst Pressure:

23,000 psi (1600 bar)

Filter Element Collapse Pressure:

290 psid (20 bar) minimum per ISO 2941

Temperature Range:

Nitrile seals -45°F to 225°F (-43°C to 107°C)

Fluorocarbon seals -20°F to 250°F (-29°C to 120°C)

140°F (60°C) maximum in HWCF or water-glycol fluids

Dry Weights:

S length— 33 lbs. (15 kg)

T length— 39 lbs. (17.7 kg)

Filter Element Collapse Pressure:

9100—290 psid (20 bar)

9101—3000 psid (207 bar)

9104—150 psid (10 bar)

Dimensional Drawings

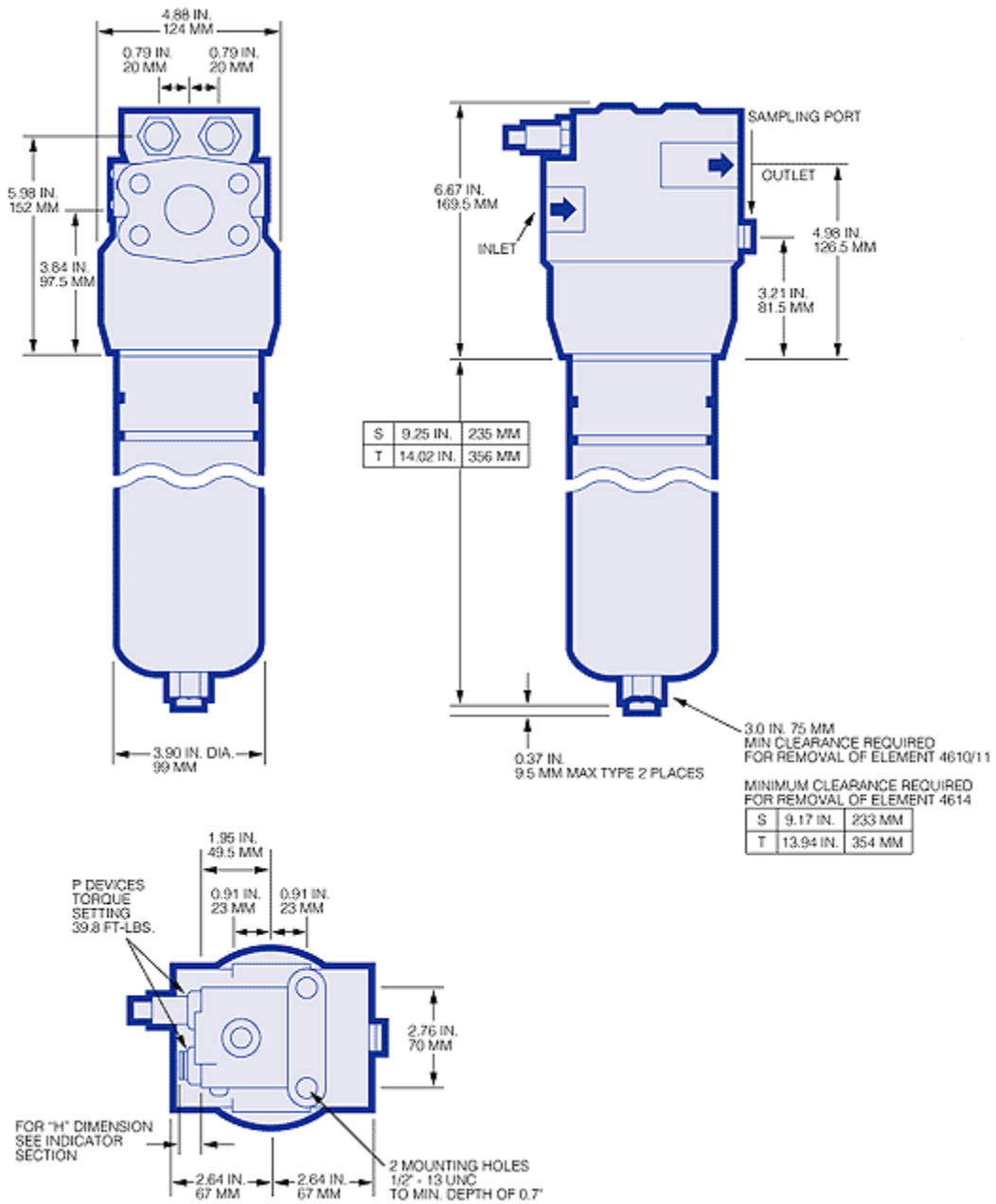

Performance

Figure 1. Housing Pressure Drop using fluid with 0.9 S.G. Housing Pressure drop is directly proportional to specific gravity.

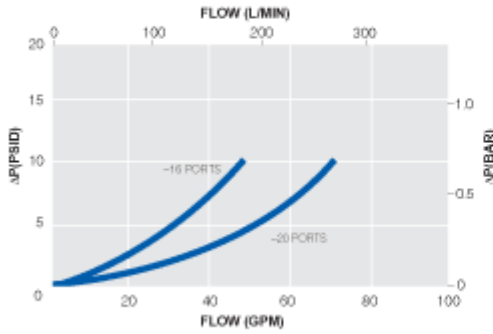
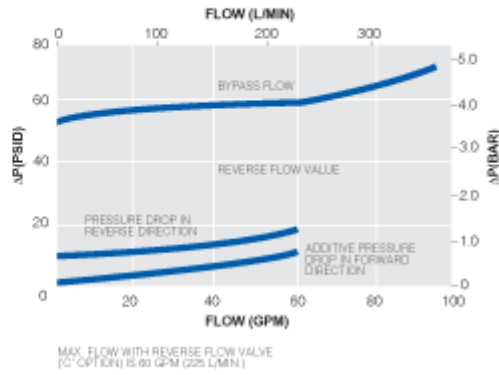

Figure 2. Bypass Valve Pressure Drop using fluid with 0.9 S.G. Bypass valve pressure drops are directly proportional to specific gravity.



Element Pressure Drop Factor

Multiply actual flow rate times factor to determine pressure drop with fluid at 150 SUS (32 cSt), 0.9 S.G. Correct for other viscosities by multiplying new viscosity in SUS/150 x new S.G./0.9.

9100/9104 Series Element ΔP factor (psid/gpm)

Length	KZ	KP	KN	KS	KT
8"	0.53	0.25	0.21	0.16	0.11
13"	0.32	0.14	0.11	0.09	0.06

9101 Series Element ΔP factor (psid/gpm)

Length	DP	DT
8"	0.55	0.23
13"	0.34	0.16

Ordering Information

Assembly P/N: H 461 3
Table1 Table2 Table3 Table4 Table5 Table6 Table7 Table8

Element P/N: HC 910 F
Table2 Table5 Table6 Table1

Note: Choose from the options in the following tables to compile the specific Product Number.

TABLE 1: SEAL OPTIONS

Code	Seals
H	Nitrile
Z	Fluorocarbon

TABLE 2: ELEMENT OPTIONS

Code	Rating
0	290 psid (standard)
1	3000 psid (high collapse)
4	150 psid (coreless)

TABLE 3: PORT STYLE OPTIONS

Code	Port Style
A	SAE J514 straight thread
D	Flange SAE J518c-Code 61
E	Flange SAE J518c-Code 62

TABLE 4: PORT SIZE OPTIONS

Code	Size
16	1"
20	1-1/4"

TABLE 5: FILTER ELEMENT OPTIONS

Code	$\beta_x \geq 200$	$\beta_{x(c)}=1000$
KZ	<1	2.5
KP	3	5
KN	6	7
KS	12	12
KT	25	22
DP*	3	5
DT*	17	15

*4611 only

*Indicators fatigue rated at 3000 psi. For cyclic pressures above 3000 psi, stainless steel indicators are necessary. Designate with an 'H' in model Code (e.g., PH, DH, etc.).

TABLE 6: LENGTH OPTIONS*

Assembly Code	Element Code**
S	8
T	13

* Use Code in second column for element part no.

** Nominal length in inches.

TABLE 7: BYPASS VALVE OPTIONS

Code	Description
B	50 psid- 4610/14 only
C	50 psid bypass with reverse flow-4610 only
W	Non-bypass- 4611 only
K	Non-bypass with reverse flow-4611 only

TABLE 8: DIFFERENTIAL PRESSURE DEVICE OPTIONS

Code	Description
P	Visual indicator with thermal lockout
D	Visual indicator with no thermal lockout
L	Electrical switch (SPDT) with 6" leads
T	Electrical switch with DIN connector
M	'T' type switch with matching wiring cap
S	Electrical switch with MS receptacle
V	Combined visual/electrical with DIN connector
B	Plug in place of indicator
2	'P' and 'L'
3	'P' and 'S'
